

Hoffman Specialty[®] Vacuum Heating Units Series HV[™] (1,000-20,000 Sq. Ft. EDR)

SERIES HV UNITS
1,000 – 20,000 SQ. FT/. EDR

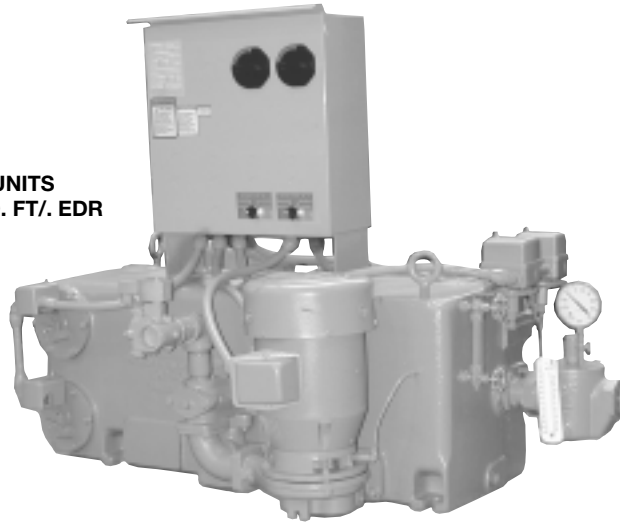

INSTALLER: PLEASE LEAVE THIS MANUAL FOR THE OWNER'S USE.



SAFETY INSTRUCTIONS

This safety alert symbol will be used in this manual and on the unit safety instruction decals to draw attention to safety related instructions. When used, the safety alert symbol means **ATTENTION! BECOME ALERT! YOUR SAFETY IS INVOLVED! FAILURE TO FOLLOW THESE INSTRUCTIONS MAY RESULT IN A SAFETY HAZARD.**

If the decals as noted below are missing or are illegible contact your local B&G representative for a replacement.

1. Electrical connections to be made by qualified Electrician in accordance with all National, State and Local codes.
2. Motor must have properly sized starter with properly sized heaters to provide overload and undervoltage protection.
3. If pump, motor or piping are operating at extremely high or low temperatures, guarding or insulation is required.
4. Operating personnel should be trained in the operation of pumps and associated systems (condensate, boiler feed, etc.).



(2) All Units
DN0483 (Small) - DN0484 (Large)



(2) All Units
DN0485 (Small)
DN0486 (Large)

HOFFMAN SPECIALTY [®]		
SERIES HV [™]		
MODEL		
SERIAL		
GPM	PSI	PUMP
CFM	IN HG.	PUMP
DWGS		
POWER V.	PH.	HZ 60
CONTROL V.	PH. 1	HZ 60
TOTAL F.L. AMP	LARGEST MOTOR F.L. AMP	

DN0016
Bell & Gossett
Morton Grove, Illinois 60053

DN0116 Units with Panel

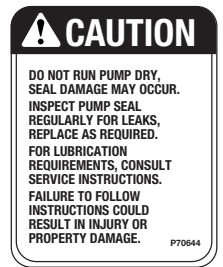

P70644 All Units

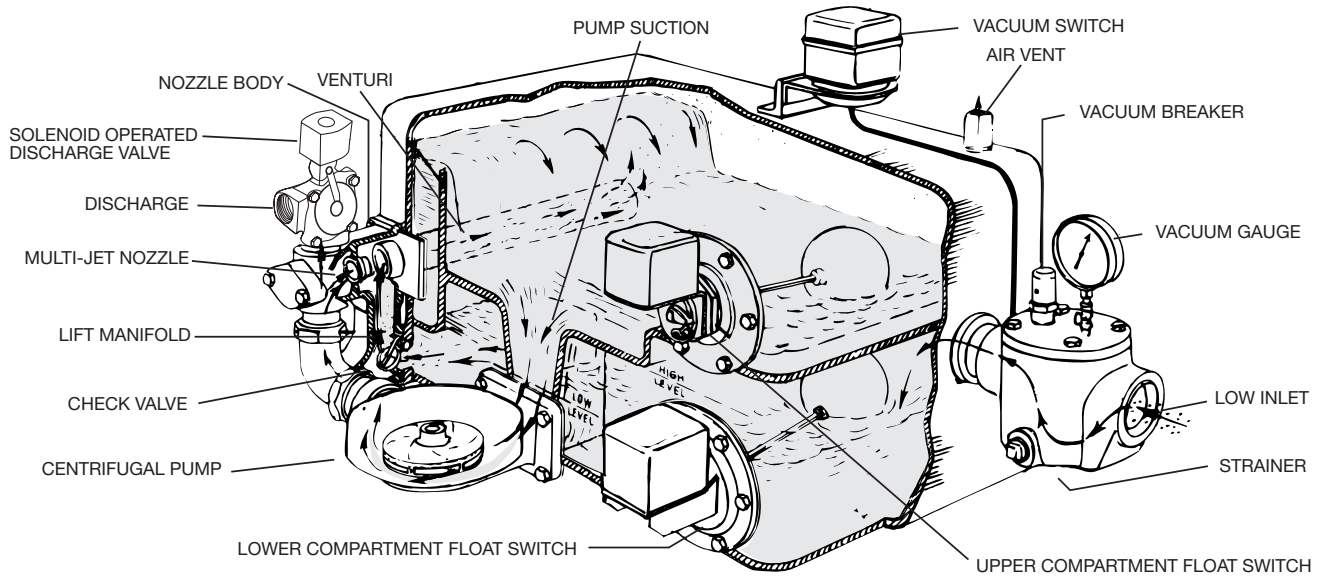

FIG. 1 CUT-AWAY VIEW OF SINGLE SERIES HV SINGLE UNIT: TYPICAL OF ALL SINGLE AND DUPLEX MODELS

DESCRIPTION AND INSTALLATION

The Series HV vacuum heating units are designed to serve the dual purpose of pumping accumulated condensate back to the boiler feed tank and maintaining vacuum in the condensate system. This vacuum will draw air out of the system on start-up and facilitate the flow of steam thru the heating system.

One pump/vacuum producer/discharge valve assembly controls both the condensate discharge and the production of vacuum. Two pump (duplex) units have a second assembly for backup and to provide extra capacity to handle peak loads.

Various electrical controls are offered to meet system requirements. These controls are normally supplied as part of the assembled unit and a wiring diagram is furnished with the unit. Refer to this electrical diagram as required.

The units respond to both changing condensate levels and system vacuum requirements. The Series HV units feature a low inlet height and therefore have a second float (in the lower compartment). As condensate accumulates in the lower compartment, this float starts the pump and siphons the condensate to the upper chamber.

In operation the centrifugal pump circulates condensate from the upper compartment thru the multi-jet nozzle creating multiple jets of water entering the venturi. These jets entrain air and gasses creating a smooth steady vacuum in the lift manifold and in the condensate system. The air and gasses are separated in the upper compartment and vented to atmosphere. See Figure 1.

Low system vacuum or high water in the upper compartment or high water in the lower compartment will start the pump to create vacuum and transfer water to the upper tank. High water level in the upper compartment will also cause the discharge valve to open.

When the vacuum and float switches have been satisfied and the pump stops, the check valve in the lift manifold closes, preventing the return of air and water to the system.

The solenoid operated discharge valve is opened in response to the condensate level float switch in the upper compartment. Controlled opening of the discharge valve holds sufficient back pressure in the nozzle body that the vacuum producer continues to function even when discharging condensate (simultaneous rating).

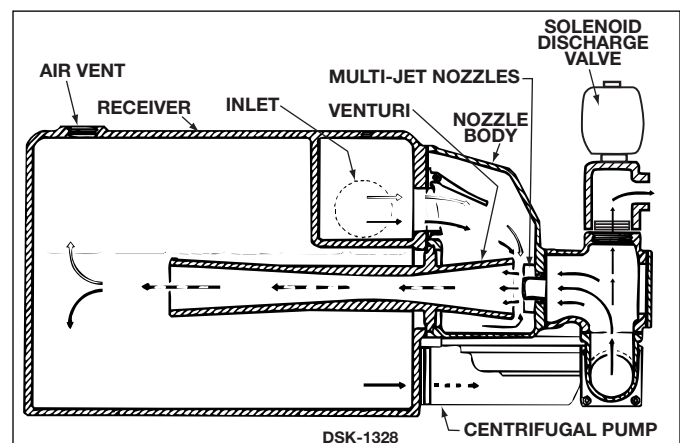
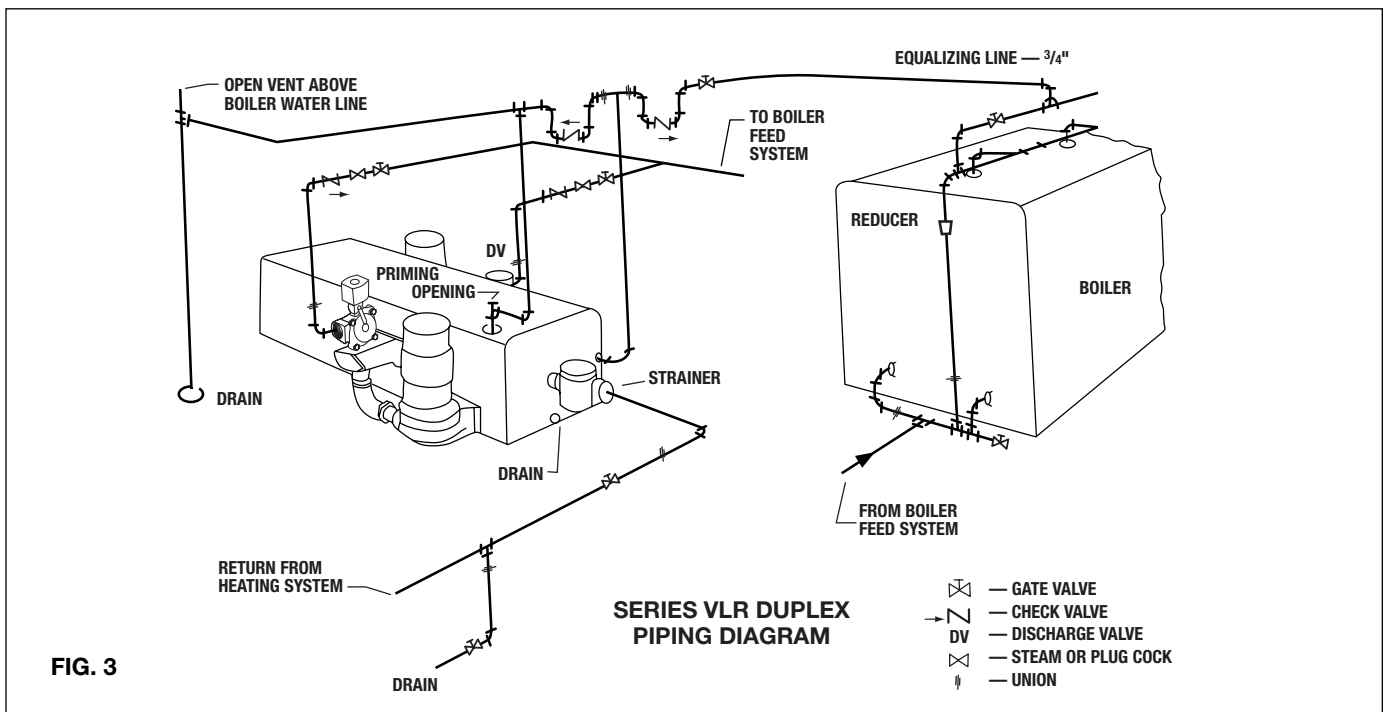

FIG. 2 SERIES HV VACUUM PRODUCER



Receivers are non-code cast iron.

WARNING: EXPLOSIBLE
 Do not pressurize receiver. Isolate receiver during leak test. Do not plug overflow. Do not restrict vent opening to atmosphere. Open valves slowly. Failure to follow these instructions could result in serious injury or death.

PRELIMINARY INSPECTION

Assure that there is no shipping damage.

Assure that nameplate ratings agree with job specifications and actual conditions.

HANDLING

Use care in installing unit.

CAUTION: UNIT LIFTING EYE
 Use unit lifting eyes only to lift unit as shipped from factory. Unit must be empty and disconnected from pipes, anchors and other restraints. Use proper rigging procedures. Failure to follow these instructions could result in injury or property damage.

LOCATION

Place unit for easy access to all parts. Allow adequate space for servicing. Check ambient conditions.

NOTICE / TEMPERATURE LIMITS

Motors are designed to operate in 104°F max. ambient. Insulate or ventilate as required.

PIPING (GENERAL)

Pipe the unit per the Elementary Piping Diagram. Locate and support piping so as to not load the discharge valve.

CAUTION: NOT A CHEMICAL PUMP
 Inject boiler feed compounds from chemical feed tank into boiler feed piping – never into condensate tank. Failure to follow these instructions could result in injury or property damage.

PIPING (Vent)

Install a vent pipe to atmosphere. Pipe to be size of vent port on unit. Do not restrict or reduce vent opening or exceed 20 feet vertical height unless an overflow connection is provided.

PRIMING PORT

Provide a priming port as shown on piping diagram.

FLOAT SWITCHES

Floats are locked in place to prevent damage during shipment. Remove shipping locks. Check factory settings. Floats are adjustable for various levels of operation.

See page 7 for detailed instructions.

EQUALIZING LINE

An equalizing line must be installed with all Series HV units. This line must be installed to prevent formation of a vacuum on the radiation side of the system when steam stops flowing in the mains. This vacuum may be higher than return line vacuum, which would prevent condensate from flowing back to the pump. To correct this in an unzoned system, install equalizer line as shown in the piping diagram. To correct this in a zoned system, install a vacuum breaker on supply line on radiation side of each zone control valve.

FIG. 4

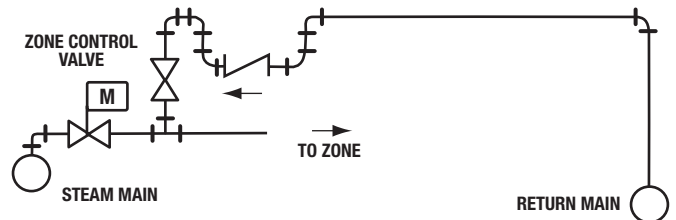

EQUALIZING CONNECTIONS FOR ZONED SYSTEMS

PIPING (Returns)

Gravity return lines from system must be properly pitched down to unit inlet. Returns must also be trapped to prevent steam entry into the unit. An inlet basket strainer is recommended.

Install gate valve in return line for testing pump shut off vacuum, closing off hot returns when cleaning strainer, etc. Do not install check valve in return line. Avoid elbow or tee located closer to strainer inlet than 10 times inlet diameter. If unavoidable relocate vacuum switches to top of nearest “dry” point on return main unless a portion of return is below pump inlet an accumulation tank is recommended. Accumulator tank may not be necessary if low length of return is not lower than 24" below pump inlet or longer than 30". See TYPICAL PIPING-LOW RETURNS. High pressure steam traps should empty into uninsulated flash tank where condensate will cool before entering unit.

DISCHARGE LINE

Install union, check valve, steam cock and gate valve at unit in each discharge line. Steam cock to be adjusted to cause

pump to operate at specified pressure. If discharge line is more than 100' long, install pipe 1 or 2 times larger than discharge valve tapping.

ELECTRICAL WIRING & CONTROLS

Connect power wiring per NEC. Recheck nameplate vs. specifications and conditions. All single phase motors have internal thermal protection.



WARNING: HIGH VOLTAGE ELECTRICITY

Disconnect and lock out power before connecting or servicing unit. Failure to follow these instructions could result in serious injury or death.

Three phase motors must use starters with properly sized overload relays. Overload relays furnished are designed for manual reset.

PUTTING THE UNIT INTO SERVICE

1. Assure that the unit is piped in accordance with instructions.



WARNING: EXPLOSIBLE

Do not pressurize receiver. Isolate receiver during leak test. Do not plug overflow. Do not restrict vent opening to atmosphere. Open valves slowly. Failure to follow these instructions could result in serious injury or death.

2. Isolate tank before performing any system leak test. Do not pressurize the tank as part of the leak test. Failure to do this can result in serious injury or death.
3. Check floats for free operation.
4. Check power leads in accordance with wiring diagram enclosed in control cabinet (when furnished).



WARNING: HIGH VOLTAGE

Disconnect and lock out power before connecting or servicing unit. Failure to follow these instructions could result in serious injury or death.

5. Install drain plugs.
6. Fill receiver (upper compartment on Series HV) half full of water to prime pump(s) and prevent possible damage to pump seals. Avoid freezing conditions after unit receiver has been filled.
7. Check for proper rotation of all three phase motors. Rotation must be clockwise looking down on the motor as indicated by directional arrow on pump casting. If pump runs backwards, interchange two wires (3 phase only).



CAUTION: DO NOT REVERSE

Reverse operation can cause extensive damage to pumps. Jog the motor to test for direction of rotation. Failure to follow these instructions could result in injury or property damage.

8. Throttle plug cock in discharge line until pressure at pump (while pump is discharging) approaches pump rated pressure. Tighten plug nut to secure adjustment.



CAUTION: DO NOT RUN DRY. SEAL DAMAGE MAY OCCUR.

Inspect pump seal regularly for leaks. Replace as required. Failure to follow these instructions could result in injury or property damage.

9. Remove start-up label (below) from panel (if applicable) after complying with instructions.

ELECTRICIAN/INSTALLER/OPERATOR

REMOVE AND DESTROY THIS TAG AFTER —

1. ASSURING THAT ALL PUMPS ROTATE CLOCKWISE PER ARROWS CAST ON VOLUTES. (JOG PUMP MOMENTARILY TO TEST – INTERCHANGE ANY TWO MOTOR POWER WIRES TO REVERSE 3PH MOTORS.)
2. ASSURING THAT SHIPPING LOCKS HAVE BEEN REMOVED FROM ALL FLOAT SWITCHES.

10. If possible, observe operation thru several cycles using selector or vacuum switch settings as noted below.

SELECTOR OR VACUUM SWITCH SETTINGS

The vacuum switches are adjusted and tested at the factory for proper operation. The vacuum switch on a single unit and the lead switch of a duplex unit is set to close at 3" Hg vacuum and open at 8". The lag switch of a duplex unit is set to close at 2" and open at 8".

These settings are suitable for all normal installations including those having an accumulator tank or lift fitting. If settings must be readjusted refer to manufacturer's instructions.

POSITION	WHEN USED	OPERATION
“Vacuum and Float” or “FI-Vac”	Normal position	Pumps operate on either low vacuum or high condensate
“Float Only” or “Float”	Sometimes used for night and week-end service. This setting not recommended for use with lift fitting.	Pump starts and stops on Condensate level change
“Continuous” or “Hand”	Testing and for unusually high lift conditions in return lines.	Continuous
“Off” (Duplex Units only)	Adjust controls, inspect pump	Prevent operation of motor

SPECIAL PIPING ARRANGEMENTS FOR LOW RETURNS (IF LIFT EXCEEDS 5 FEET, A MECHANICAL LIFT IS RECOMMENDED)

CONNECTIONS TO VACUUM UNIT WHERE HEATING UNITS ARE ABOVE THE WATER LINE OF BOILER AND A SECTION OF THE RETURN IS BELOW THE PUMP INLET

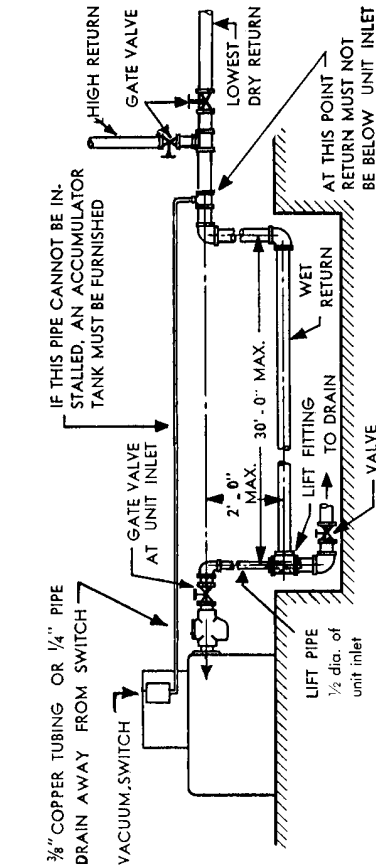

FIG. 5

RETURNS BELOW UNIT INLET (NO ACCUMULATOR TANK) VACUUM PUMP TO RUN CONTINUOUSLY.

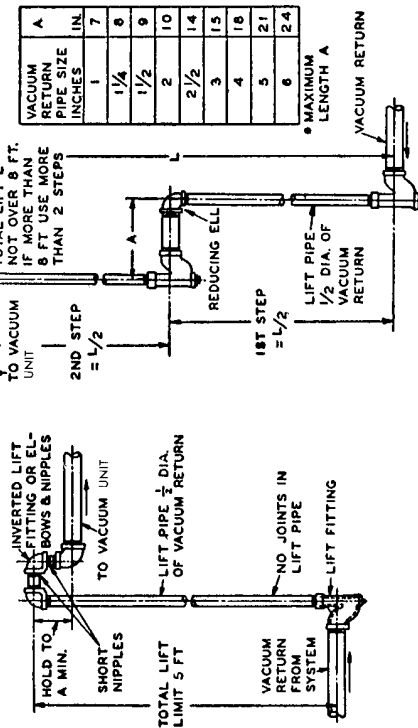

FIG. 6 METHOD OF CONSTRUCTING A LIFT IN A RETURN LINE

FIG. 7 CONSTRUCTION OF A STEP LIFT

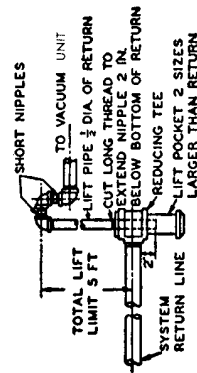

FIG. 8 HOW TO BUILD A LIFT FITTING

LIFT PIPE DETAIL reprinted by Permission FROM HEATING, VENTILATING, AIR CONDITIONING GUIDE, 1957.

Note—A valve or cock is recommended to drain lift fitting.

PIPING TO VACUUM UNIT WHERE RETURN MAIN IS BELOW PUMP FLOOR LEVEL WITH CONNECTIONS TO PITTED AND VERTICAL UNDERGROUND ACCUMULATOR TANKS.

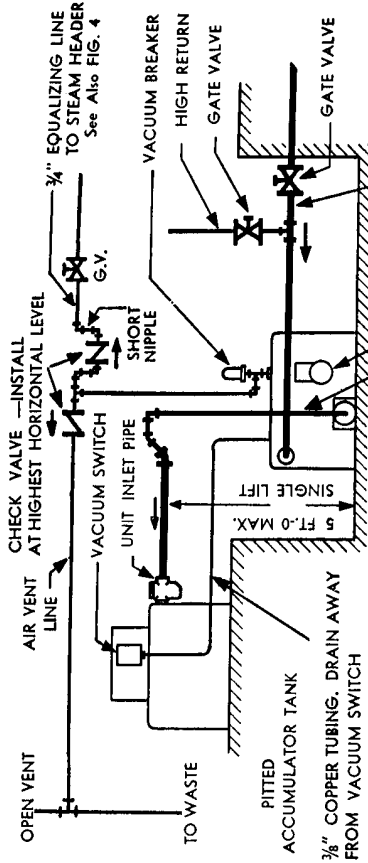

FIG. 9

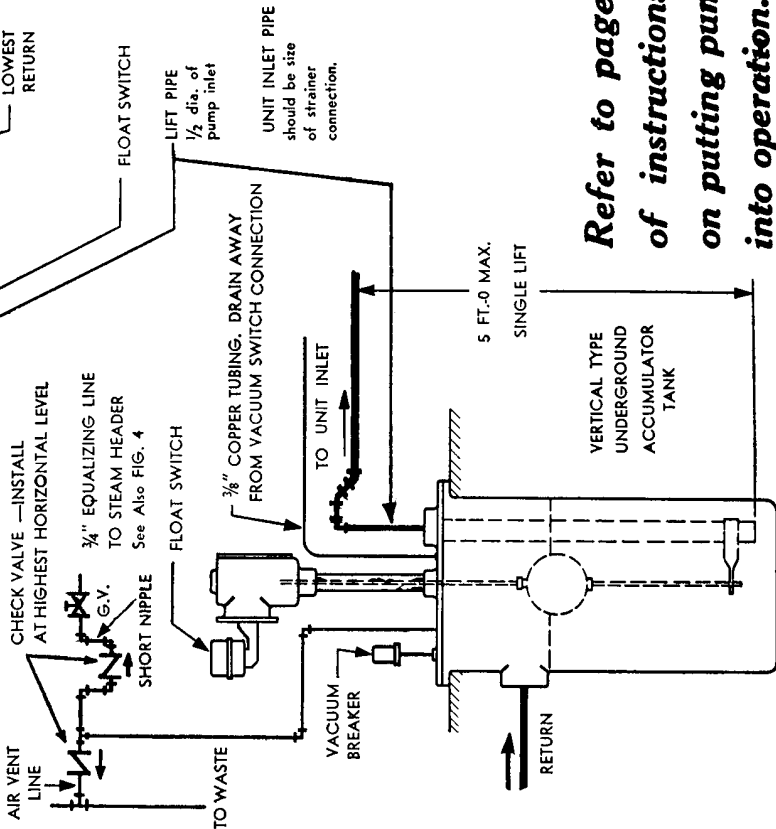

FIG. 10

Refer to page of instructions on putting pump into operation.

OPERATION AND MAINTENANCE

Operators must be familiar with all sections of this manual to understand the operation of the unit.

Hot water, steam and electricity can be hazardous.



SAFETY INSTRUCTIONS
SEE COVER OF THIS MANUAL



WARNING: EXPLOSIBLE

Do not pressurize receiver. Isolate receiver during leak test. Do not plug overflow. Do not restrict vent opening to atmosphere. Open valves slowly. Failure to follow these instructions could result in serious injury or death.



WARNING: HIGH VOLTAGE

Disconnect and lock out power before connecting or servicing unit. Failure to follow these instructions could result in serious injury or death.

LUBRICATION

The only pump bearing requiring lubrication is the ball bearing in the motor support just below the flexible coupling. It has a reservoir, which is filled with moisture resistant high temperature grease.

Remove pipe plug in motor support and add approximately 3 ounces of Shell Alvania RL 2 grease (or equivalent) from once a year (normal) to twice a year for extremely hot conditions. Do not use ordinary grease.

NOTICE / AUTO RESTART

Single phase motors will restart automatically after thermal overload protector trips.

Overload thermal relays in starters must be reset manually.

A properly installed unit should function unattended for long periods of time. Periodic checks to assure proper operation are highly recommended. Refer to trouble shooting section when necessary.

A variety of control options are available and are furnished in accordance with user specifications. Refer to wiring diagrams (when furnished) to determine control switch settings.

The inlet strainer (when furnished) is intended to protect the pump and system. Periodic cleaning should be included in the maintenance schedule. Check frequently in new systems.



CAUTION: SUBSEQUENT DAMAGE

A unit showing symptoms of possible problems (overflow, noise, leaks, vibrations, continual operation, etc.) must be corrected immediately. Failure to follow these instructions may result in full liability for subsequent injury or property damage.

GAGE GLASS MAINTENANCE (Vented Systems)

Clean gage glass as required using commercial glass cleaner. Dilute muratic acid may be used if required (observe handling precautions). Never clean gage glass with wire brushes, scrapers or harsh abrasives.

Do not reuse gage glass or packings or seals.

Immediately replace glass which is broken, cracked, chipped, scratched or otherwise damaged. Inspect periodically with a bright concentrated light. Anything which glistens and catches the fingernail or any star-shaped or crescent-shaped mark which glistens is cause for replacement. Any gage glass which appears cloudy or roughened and will not respond to cleaning procedures should be replaced.

When replacing gage glass, use new packings specified for this use. Install glass with sufficient end clearance for expansion (keep glass to metal clearance at each end) and tighten nuts just enough to avoid leakage (do not over tighten).

INLET BASKET STRAINER MAINTENANCE

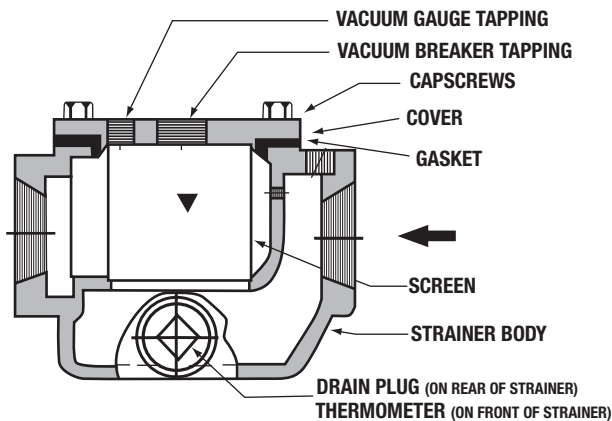

FIG. 11

Condensate enters the screen from the bottom and flows outward from the inside. Foreign matter intercepted by the screen may drop into the large dirt pocket in the lower portion of the strainer body; however, grease, oil, gasket material and other foreign substances present in all heating systems are likely to stick and clog the strainer screen. For this reason it may be necessary to clean the strainer several times a week during the first few months of operation.

To clean strainer proceed as follows: (1) open disconnect switch(es), (2) close return line gate valve, (3) remove drain plug, (4) remove cap screws, cover and screen, (5) clean screen thoroughly, (6) flush strainer body and dirt pocket, (7) inspect gasket, (8) reassemble.

While the pump is shut down inspect and clean the multi-jet nozzles as follows: (1) drain receiver below nozzle level by removing drain plug, (2) remove discharge manifold cover plate and multi-jet nozzle, (3) clean nozzle, (4) inspect gasket and reassemble, (5) reprime pump to half way level in gauge glass, (6) close switches, (7) open return line gate valve slowly.

FLOAT SWITCH ADJUSTMENT PROCEDURES

CONTROLS ARE PRESET AT THE FACTORY BUT MAY VARY DUE TO HANDLING DURING SHIPMENT.

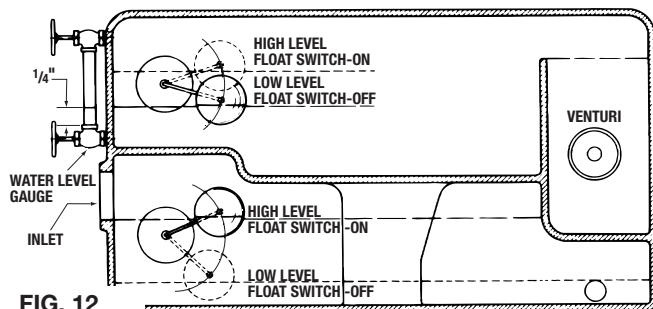

PROPER ADJUSTMENT OF CONTROLS ASSURES BEST PERFORMANCE.

1. Close the inlet gate valve and operate the pump on CONTINUOUS to remove as much water as possible from the receiver. Open disconnect switch(es).
2. Adjust cut-off point of lower compartment float switch so that switch opens just before float touches bottom of receiver. Both switches of duplex units should open at same low level. (See switch manufacturer's instructions for procedure).
- 3a. (One float switch in lower compartment.) Remove strainer cover and fill lower compartment thru strainer. Close inlet valve and remove drain plug from strainer. When water stops flowing from drain opening adjust cut-in point of lower float switch by depressing float arm slightly and setting adjusting strip so that switch turns on when float arm is released.
- 3b. (Two float switches in lower compartment.) Adjust cut-in point of second switch so that operating range is approximately 2 divisions narrower than range for switch adjusted in 3a.
4. Adjust cut-off point of upper compartment float switch so that switch opens when there is about 1/4" water in gauge glass. Check as follows: (1) close discharge gate valve, (2) fill top compartment until upper float switch closes, (3) close inlet valve, (4) set selector switch on FLOAT ONLY, (5) open discharge gate valve. When float switch opens and pump stops, level should be 1/4" in gauge glass.
5. Adjust the cut-in point of the upper compartment switch by setting it for minimum level change.

PUMP SERVICE INSTRUCTIONS FOR VACUUM PRODUCING CENTRIFUGAL PUMPS

Close coupled centrifugal pumps are designed for years of trouble free service. Units have mechanical shaft seals and are vertically mounted to put the motor above floor dirt and water.

1. Drain hurling chamber.



CAUTION: HOT SURFACE

Surfaces are hot when system is in operation. Do not touch hot receiver, let unit cool before servicing. Failure to follow these instructions could result in serious injury or death.

2. Shut-off and lock out power.



WARNING: HIGH VOLTAGE

Disconnect and lock out power before connecting servicing unit. Failure to follow these instructions could result in serious injury or death.

3. Make sure unit is cool enough that pump can be handled safely. Open drain to remove remaining liquid.
4. Carefully remove pump drain plug and bleed line. Wait for complete drainage.
5. Loosen the motor bracket to pump volute capscrews. Assure that the pressure is relieved per caution note.



CAUTION: PRESSURIZED SYSTEM

Operating system may contain very hot water. Close inlet and open drains before servicing. When servicing, *loosen* screws and move components to assure pressure is relieved before *removing* screws. Keep drains open during servicing. Failure to follow these instructions could result in injury or death.

6. Complete the removal of the hardware. Remove pump/motor assembly and place on work bench.
7. Remove self locking stainless steel capscrews and stainless steel washer (or self locking brass cap nut and washer) that secure the impeller in place.
8. To remove impeller from motor shaft proceed as follows:
 - (1) Keyed Shafts. Remove impeller with gear puller or other means which will not damage impeller or bend motor shaft.
 - (2) Threaded Shafts. Hold end of motor shaft opposite pump with large screwdriver or other suitable tool and back impeller off with a rectangular bar or other flat tool inserted between the vanes of the impeller.
9. Remove rotating part of seal from shaft, being careful not break carbon face.
10. Remove capscrews holding motor bracket to motor and remove bracket.
11. Remove stationary part of seal assembly, being careful not to chip or break ceramic seal.
12. To install seal proceed as follows:
 - (1) Clean recess in bracket thoroughly. Coat recess and "rubber" portion of seat with soap solution. Press seat into recess firmly by hand making certain both parts bottom evenly. If seal cannot be bottomed with fingers place cardboard shipping disc on ceramic and force into place with tool.
 - (2) Carefully place bracket in position on motor shaft without displacing ceramic seat and secure bracket to motor with capscrews.

- Place motor vertically with pump end up. Do not attempt assembly of seal and impeller with shaft horizontal.

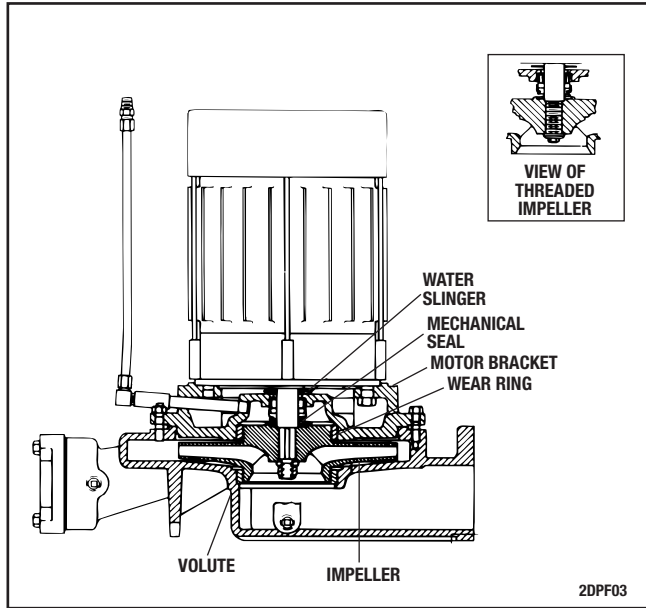

- The “carbon” of rotating part of seal should not be loose. If it is, hold in place with grease. Using clean, lint free cloth, wipe mating surfaces perfectly clean. Soap shaft and push seal onto shaft so that carbon will contact ceramic seal. If spacer is required, use grease to cause spacer to adhere to bottom of seal after seal has been put on shaft, Be sure spacer is on larger diameter of shaft so that will not catch between shoulder and impeller.

- Replace impeller on shaft. Replace stainless steel washer and secure impeller with capscrew or cap nut.
- Place new gasket on pump volute and reassemble motor and pump subassembly on pump volute.
- Reconnect pump bleed line and motor wiring.



**CAUTION: DO NOT RUN DRY.
SEAL DAMAGE MAY OCCUR**

Inspect pump seal regularly for leaks. Replace as required. Failure to follow these instructions could result in serious injury or death.

- Close drain and slowly open inlet valves. See warning.



WARNING: EXPLOSIBLE

Do not pressurize receiver. Isolate receiver during leak test. Do not plug overflow. Do not restrict vent opening to atmosphere. Open valves slowly. Failure to follow these instructions could result in serious injury or death.

- Jog to check motor rotation. See caution.



CAUTION: DO NOT REVERSE

Reverse operation can cause extensive damage to pumps. Jog the motor to test for direction of rotation. Failure to follow these instructions could result in serious injury or death.

- Observe operation thru several cycles.

TROUBLESHOOTING SERIES HV UNITS

ALL UNITS ARE THOROUGHLY TESTED AT THE FACTORY BEFORE SHIPMENT AND SHOULD OPERATE SATISFACTORILY WITHOUT FURTHER ADJUSTMENT IF PROPERLY INSTALLED AND IF NOT DAMAGED BY ROUGH HANDLING IN TRANSIT. IF SYSTEM OR UNIT PERFORMANCE IS NOT SATISFACTORY, REFER TO THE FOLLOWING CHECK LIST.

PUMP WILL NOT START

- The power supply has been interrupted, disconnect switch is open or selector switches improperly positioned.
- Insufficient condensate has accumulated to actuate float switch.
- Vacuum is not low enough to actuate vacuum switch.
- Incorrect voltage for motor. Check voltage and wiring with motor characteristics.
- Incorrect starter coil for power supply.
- The overload relays in the starter have tripped out and must be reset. Ambient temperature may be too high.
- Check float switch, vacuum switch or other control for proper operation.
- Wiring to control panel is incorrect or connections are loose.

PUMP DOES NOT RETURN ALL CONDENSATE TO BOILER FEED SYSTEM (SYSTEM FLOODS)

- Pump is running backward looking down on motor. Rotation of 3 phase motors may be corrected by interchanging any two of the three wires. Pump should run clockwise.
- Steam traps are blowing through causing condensate to return at excessive temperatures. If 160°F is exceeded the capacity of the pump may be reduced below its rating. Traps should be repaired or replaced.

- The total pressure at the pump discharge is greater than the pressure for which the pump was designed. Check the total pressure which includes the boiler pressure, the friction head and the static head.
- A valve in the discharge line between pump and boiler is closed or throttled too tightly. Check valve is installed backwards.
- Condensate is held up in system periodically by induced vacuum in boiler or radiation then released in a flood when the pump starts. Install equalizer line.
- The strainer is dirty thus retarding flow. Refer to instructions for cleaning.
- The impeller eye is clogged with trash. Clean.
- The bellows type discharge valve fails to open. This may be caused by the solenoid valve remaining in a closed position, or dirt becoming lodged in the pressure release line. Float switch failure may also cause the discharge valve to remain shut. Replace the bellows type discharge valve with the solenoid operated discharge valve. If solenoid discharge valve has already been installed the solenoid may be stuck shut or the float switch failed.
- Systems with accumulator tanks should have equalizer line run from accumulator tank to steam header NOT from accumulator tank to pump receiver NOR from pump receiver to steam header. Install vacuum breaker on accumulator tank, NOT on pump.
- Pump is too small for the system.

VACUUM PUMP RUNS CONTINUOUSLY OR FAILS TO PRODUCE SUFFICIENT VACUUM*

1. Selector switch is set on "continuous" or "hand".
2. The temperature of the condensate is too high. Normal operating condensate temperature should not exceed 160°F for rated capacities. Correct the cause for high temperature condensate.
3. There are excessive leaks in the system piping preventing the pump from producing sufficient vacuum to satisfy the vacuum switch setting. To confirm this, make sure pump is primed, close inlet valve, close equalizing line valve, plug other check valve on this line, replace vacuum breaker with plug and observe shut-off vacuum while pump is running.
4. The vacuum or float switch electrical contacts remain in closed position. Adjust controls.
5. The nozzle, strainer, or impeller passageways are clogged with foreign matter. Refer to instructions for cleaning.
6. A vacuum breaker is set too low. It should not admit air at a vacuum within the range of the vacuum switch setting.
7. The pump has lost its hurling water. There should never be less water than shown on float adjustment sketch. Loss of hurling water may be caused by:
 - (1) Discharge valve leaks due to dirt or worn seat.
 - (2) Orifice in guide screw in discharge valve is closed.
 - (3) Discharge valve bellows is ruptured.
 - (4) Solenoid pilot valve remains in open position.
 - (5) Float switch failure.Replace the bellows discharge valve with the solenoid operated discharge valve. If the valve has already been replaced with the solenoid operated discharge valve the loss of hurling water may be caused by:
 - (1) Solenoid discharge valve leaks due to dirt or worn seat.
 - (2) Solenoid discharge valve stuck in open position.
 - (3) Check valve in nozzle body is leaking.
 - (4) Float switch failure.
8. Check valve in equalizer line or air vent line from receiver or accumulator tank leaks, or is installed backwards.
9. One nozzle body check valve, Figure 2, page 2, on duplex pump remains open, permitting air to recirculate.
10. Pump is too small for the system.
11. Lower float switch does not turn off. Float rests on receiver bottom and should be raised.

PUMP STARTS AND STOPS IN RAPID SUCCESSION

1. A check valve in return line. Remove.
2. A partially closed inlet valve. Valve should be a gate valve rather than globe.
3. A lift in return line at or near the pump. Low return lines will fill with condensate between pump operations. The inertia of the collected water may be quite great, and before the vacuum suddenly produced by starting of the pump can set the water in motion, the vacuum at the pump may reach the cut-off point of the vacuum switch, thus stopping the pump. The vacuum quickly recedes as the condensate moves into the receiver and the pump "trips in" on vacuum control again, thus repeating this "hunting action". There are two ways to correct this difficulty:
 - (1) If the vacuum sensing line can be drained away from the vacuum switch(es), connect this sensing line into the nearest "dry" point in the return main so that the operation of the unit may be governed by the vacuum in the system.

- (2) If the nearest "dry" point on the return main is more than 2 ft. above the vacuum switch, relocate and reconnect the switches to sense the vacuum at this point. If a separate selector switch for "FI-Vac", "Float", "Hand" operation is not already furnished with the unit, one must be provided for each vacuum switch for installation in control panel.
4. Elbow in return line too close to unit inlet. Correct as described in item 3, or if there is no lift in the return line at or near the pump, extend the 3/4" equalizing line to top of "dry" point on return main.
5. Equalizer line is improperly connected.
6. Strainer clogged with dirt. Clean strainer.

PUMP MAKES NOISE

1. The pump is working against a lower pressure than designed for. While pump is discharging, adjust square headed steam cock in discharge line until pressure at pump approaches pump rated pressure. Secure adjustment of steam cock by tightening lock nut.
2. Excessive condensate temperature. Correct system conditions.
3. Magnetic hum or bearing noise in motor. Consult motor manufacturer's authorized service station nearest pump location.
4. Starter chatters. Trouble is caused by low line voltage, poor connections, defective starter coil, or burned contacts.
5. Pump is running backward.
6. Water hammer when discharge valve closes:
 - (1) Adjust steam cock to reduce discharge velocity or
 - (2) Install surge chamber on boiler side of discharge check valve or
 - (3) Install additional check valve near boiler or
 - (4) Install discharge piping 1 or 2 sizes larger.

THE SYSTEM IS NOISY

1. Banging in the steam main is usually caused by "implosion" in condensate lying in low points in lines. These pockets can be eliminated by "dripping" low points, properly supporting the pipe, or by increasing the pitch of the lines.
2. Improper dripping of the steam mains and risers. Where there is a rise in the steam main, or where it branches off into a riser, a drip trap must be installed to the drain line.
3. The piping is too small to drain properly.
4. A defective trap is holding condensate in radiation.
5. A priming boiler is permitting a carry-over of water with the steam. A priming boiler is caused by:
 - (1) Oil or other foreign matter. Clean boiler thoroughly.
 - (2) A reduction of the steam liberating area due to too high water level in the boiler. Reduce water line.
 - (3) Overloading. Reduce firing rate.
 - (4) Undersized steam outlet area, resulting in velocities in excess of 15 to 25 ft. per second.

*Product life and product efficiency are greatly affected by system maintenance. A tight (leak-free) system with properly functioning traps is essential for efficient operation.

DEALER SERVICE

If trouble occurs that cannot be rectified, contact your local B&G representative. He will need the following information in order to give you assistance.

1. Complete nameplate data of pump and motor.
SEE RATING NAMEPLATE at right.
2. Vacuum readings.
3. Ampere draw of the motor.
4. A sketch of system piping.

HOFFMAN SPECIALTY®		
SERIES		HV™
MODEL		
SERIAL		
GPM	PSI	PUMP
CFM	IN HG.	PUMP
DWGS		
POWER V.	PH.	HZ 60
CONTROL V.	PH. 1	HZ 60
TOTAL F.L. AMP	LARGEST MOTOR F.L. AMP	
Bell & Gossett Morton Grove, Illinois 60053		
DN0016		



Xylem Inc.
 8200 N. Austin Avenue
 Morton Grove, Illinois 60053
 Phone: (847) 966-3700
 Fax: (847) 965-8379
www.xylem.com/brands/bellgossett